

Spec.No.: DDPM-M150XN07-0.1

Version: 1/3

Total pages:26

Date: 2003-Jun-20

AU OPTRONICS CORPORATION

Product Specifications

15.0" XGA Color TFT-LCD Module

**Model Name: M150XN07
V.1**

Approved by	Prepared by

DDBU Marketing Division / AU Optronics Corporation

Product Specifications

15.0" XGA Color TFT-LCD Module
Model Name:M150XN07
V.1

(◆) Preliminary Specifications
() Final Specifications

i Contents

1.0 Handling Precautions

2.0 General Description

- 2.1 Display Characteristics
- 2.2 Functional Block Diagram

3.0 Absolute Maximum Ratings

4.0 Optical Characteristics

- 4.1 Signal for Lamp connector
- 4.2 Parameter guideline for CCFL Inverter

5.0 Signal Interface

- 5.1 Module Interface Connectors
- 5.2 Module Connector Pin Configuration
- 5.3 Backlight Connectors
- 5.4 Backlight Connector Pin Configuration
- 5.5 Signal Electrical Characteristics
- 5.6 Interface Timings Characteristics
- 5.7 Interface Timing Definition

6.0 Pixel format image

7.0 Power Consumption

8.0 Power ON/OFF Sequence

9.0 Backlight Characteristics

- 9.1 Signal for Lamp connector
- 9.2 Parameter guideline for CCFL Inverter

10.0 Vibration, Shock, and Drop

- 10.1 Vibration & Shock
 - 10.1.1 Vibration Test Spec
 - 10.1.2 Shock Test Spec
- 10.2 Drop

11.0 Environment

- 11.1 Temperature and Humidity
 - 11.1.1 Operating Conditions
 - 11.1.2 Shipping Conditions
- 11.2 Atmospheric Pressure
- 11.3 Thermal Shock

12.0 Reliability

- 12.1 Failure criteria
- 12.2 Failure rate
 - 12.2.1 Usage
 - 12.2.2 Components de-rating
- 12.3 CCFL life
- 12.4 ON/OFF cycle

13.0 Safety

13.1 Sharp edge requirement

13.2 Material

13.2.1 Toxicity

13.2.2 Flammability

13.3 Capacitors

13.4 Hazardous voltage

14.0 Other requirements

14.1 Smoke free design

14.2 National test lab requirement

15.0 Label

16.0 Mechanical Characteristics

ii Record of Revision

Version and Date	Page	Old description	New Description	Remark
0.1 2003/06/10	All	First Edition for Customer	All	

1.0 Handling Precautions

- 1) Since front polarizer is easily damaged, pay attention not to scratch it.
- 2) Be sure to turn off power supply when inserting or disconnecting from input connector.
- 3) Wipe off water drop immediately. Long contact with water may cause discoloration or spots.
- 4) When the panel surface is soiled, wipe it with absorbent cotton or other soft cloth.
- 5) Since the panel is made of glass, it may break or crack if dropped or bumped on hard surface.
- 6) Since CMOS LSI is used in this module, take care of static electricity and insure human earth when handling.
- 7) Do not open nor modify the Module Assembly.
- 8) Do not press the reflector sheet at the back of the module to any directions.
- 9) In case if a Module has to be put back into the packing container slot after once it was taken out from the container, do not press the center of the CCFL Reflector edge. Instead, press at the far ends of the CFL Reflector edge softly. Otherwise the TFT Module may be damaged.
- 10) At the insertion or removal of the Signal Interface Connector, be sure not to rotate nor tilt the Interface Connector of the TFT Module.
- 11) After installation of the TFT Module into an enclosure (LCD monitor housing, for example), do not twist nor bend the TFT Module even momentary. At designing the enclosure, it should be taken into consideration that no bending/twisting forces are applied to the TFT Module from outside. Otherwise the TFT Module may be damaged.
- 12) Cold cathode fluorescent lamp in LCD contains a small amount of mercury. Please follow local ordinances or regulations for disposal.
- 13) Small amount of materials having no flammability grade is used in the LCD module. The LCD module should be supplied by power complied with requirements of Limited Power Source (2.11, IEC60950 or UL1950), or be applied exemption.
- 14) The LCD module is designed so that the CFL in it is supplied by Limited Current Circuit (2.4, IEC60950 or UL1950). Do not connect the CFL in Hazardous Voltage Circuit.

2.0 General Description

This specification applies to the 15.0 inch Color TFT-LCD Module M150XN07.

The display supports the XGA (1024(H) x 768(V)) screen format and 262,144 colors (RGB 6-bits data).

All input signals are 1 Channel LVDS interface compatible.

This module does not contain an inverter card for backlight.

Features

- XGA 1024(H) x 768(V) resolution
- 2 CCFLs (Cold cathode Fluorescent Lamp)
- High contrast ratio, high aperture ratio
- Wide viewing angle
- High-speed response
- Low power consumption

Application

Desktop monitors

2.1 Display Characteristics

The following items are characteristics summary on the table under 25 °C condition:

ITEMS	Unit	SPECIFICATIONS
Screen diagonal	[mm]	381 (15")
Outline dimension	[mm]	326.5 x 253.5 x 12.0 typ.
Display Area	[mm]	304.128 (H) x 228.096(38.1cm diagonal)
Resolution		1024(R,G,B x 3) x 768
Pixel Pitch	[mm]	0.297 x 0.297
Pixel Arrangement		R.G.B. Vertical Stripe
Display Mode		TN mode, Normally White
Typical white Luminance.	[cd/m ²]	250nit (typ) @8mA (note 1)
Brightness uniformity		80% typ. (note 2)
Luminance uniformity		1.7 max.(Note 3)
Crosstalk (at 60Hz)		1.2% max. (note 4)
Contrast Ratio		400 : 1 typ.
Support Colors		262,144 colors (6-bit for R,G,B)
Chromaticity(CIE1931)		0.313
White-x		
White-y		0.329
Color Gamut		60% typ., of NTSC coverage
Viewing angle		60(left),60(right),40(up),60(down) CR=10
Response Time	[msec]	16ms typ. (Tr +Tf)
Nominal Input Voltage VDD	[Volt]	+3.3 V
Power Consumption (VDD line + CCFL line)	[Watt]	15 (typ.) @8mA (All Black Pattern)
Electrical Interface		LVDS (1 ch)
Frame rate	[Hz]	60Hz typ., 75Hz max.
Weight	[Grams]	1100 typ.
Mounting method		Side mounting
Surface treatment		Anti-glare, hard coating (3H)
Temperature Range		
Operating	[°C]	0 to +50
Storage (Shipping)	[°C]	-20 to +60

(C) Copyright AU Optronics, Inc.

Feb. 2003 All Rights Reserved.

M150XN07 Ver.0.1

6/28

No Reproduction and Redistribution Allowed.

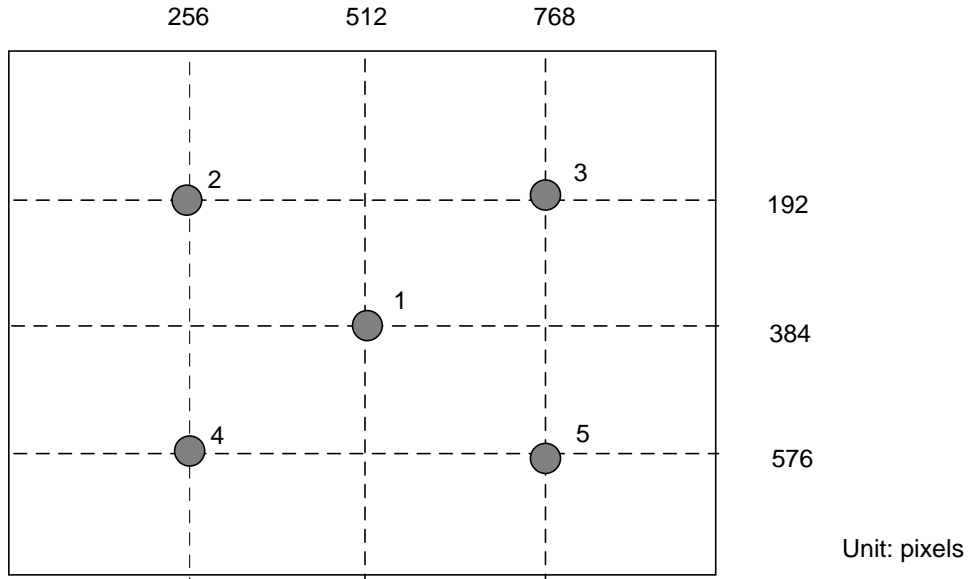

Note 1: Brightness is measured at the center point of brightness value with all pixels displaying white.

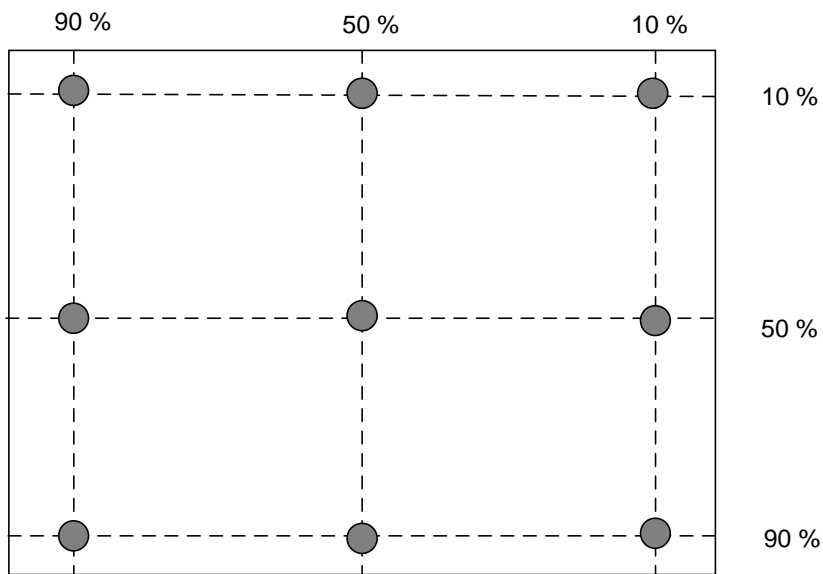

Unit: percentage of dimension of display area

Note 2: Brightness uniformity of these 9 points is defined as below:

$$(\text{Min. brightness} / \text{Max. brightness}) \times 100\%$$

Note 3: TCO '99 Certification Requirements and test methods for environmental labeling of Display Report No. 2

defines Luminance uniformity as below:

$$((L_{\text{max},+30\text{deg.}} / L_{\text{min},+30\text{deg.}}) + (L_{\text{max},-30\text{deg.}} / L_{\text{min},-30\text{deg.}})) / 2$$

TCO 99 certification requirements and test methods

1) Diagrammatic :

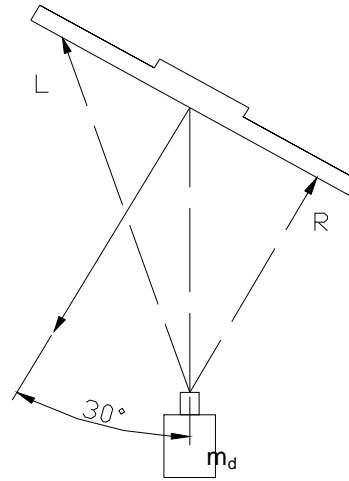
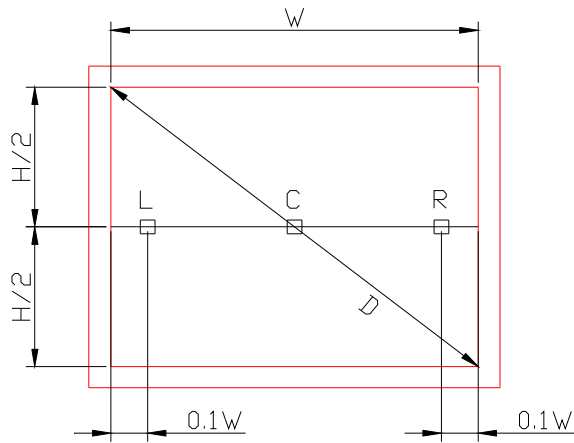

□
Measurement
Position

Effective area : $W \times H$

$L_{\max} \cdot +30^\circ$ and $L_{\min} \cdot +30^\circ$

2) D is the diagonal of the screen in centimeters. And m_d is as follow.

$$m_d(\text{cm}) = D \times 1.5 \text{ with a minimum distance : } m_d = 50 \text{ cm}$$

3) The measurement positions shall consist of an active white square of size 4 by 4 cm.

4) Measure $L_{\max} \cdot +30^\circ$ and $L_{\min} \cdot +30^\circ$ that are given as points L & R. And then rotated to an azimuth angle of -30° degrees and measure $L_{\max} \cdot -30^\circ$ and $L_{\min} \cdot -30^\circ$ again using the same procedure.

5) The variation in luminance ratio is calculated as the ratio:

$$L_R = ((L_{\max} \cdot +30^\circ / L_{\min} \cdot +30^\circ) + (L_{\max} \cdot -30^\circ / L_{\min} \cdot -30^\circ)) / 2 \leq 1.7$$

Note 4:

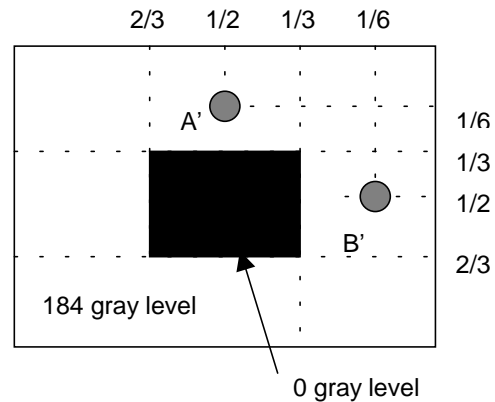
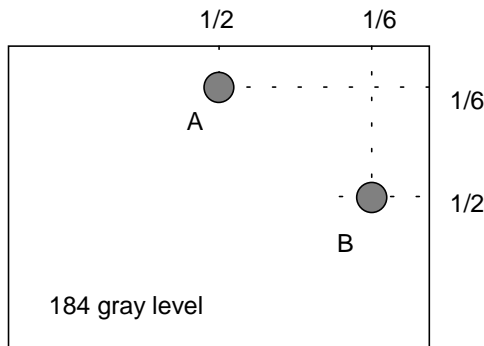

Unit: percentage of dimension of display area

$$|L_A - L_{A'}| / L_A \times 100\% = 1.2\% \text{ max., } L_A \text{ and } L_B \text{ are brightness at location A and B}$$

$$|L_B - L_{B'}| / L_B \times 100\% = 1.2\% \text{ max., } L_{A'} \text{ and } L_{B'} \text{ are brightness at location A' and B'}$$

2.2 Functional Block Diagram

The following diagram shows the functional block of 15.0 inches Color TFT-LCD Module:

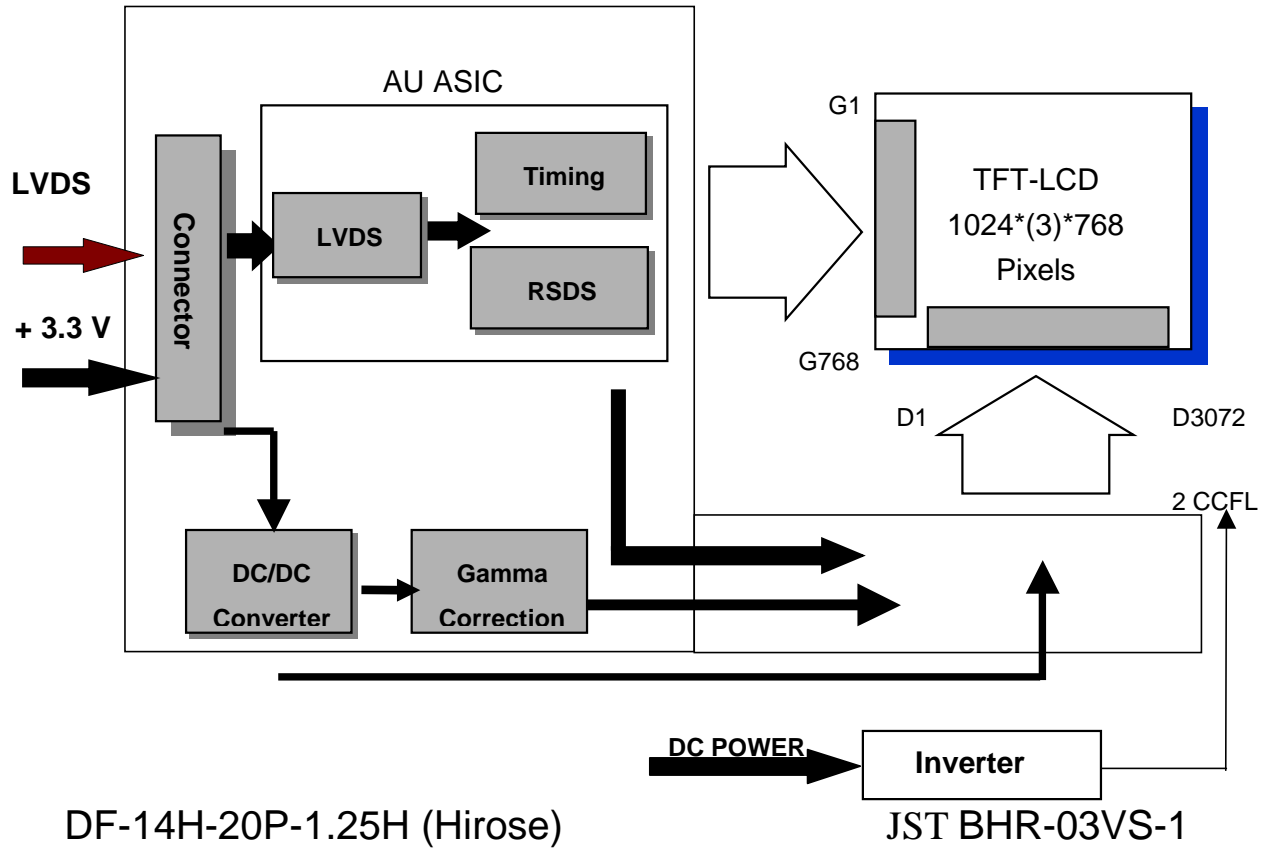

3.0 Absolute Maximum Ratings

Absolute maximum ratings of the module is as following:

Item	Symbol	Min	Max	Unit	Conditions
Logic/LCD Drive Voltage	VDD	-0.3	+3.6	[Volt]	
Input Voltage of Signal	Vin	-0.3	VDD+0.3	[Volt]	
CCFL Current	ICFL	3.0	9.0	[mA] rms	Note 1
Operating Temperature	TOP	0	+50	[°C]	Note 2
Operating Humidity	HOP	20	85	[%RH]	Note 2
Storage Temperature	TST	-20	+60	[°C]	Note 2
Storage Humidity	HST	5	95	[%RH]	Note 2
Vibration			1.5 / 10-200	[G / Hz]	
Shock			50/20	[G / ms]	Half sine wave
Assured Torque at Side Mount			2.0	[kgf.cm]	
Re-screw			3	[Times]	

Note 1: CCFL life time will drop dramatically if exceeding 8.0 mA; It will have safety concern if exceeding 9.0 mA.

Note 2 : Maximum Wet-Bulb should be 39°C and No condensation.

Wet bulb temperature chart

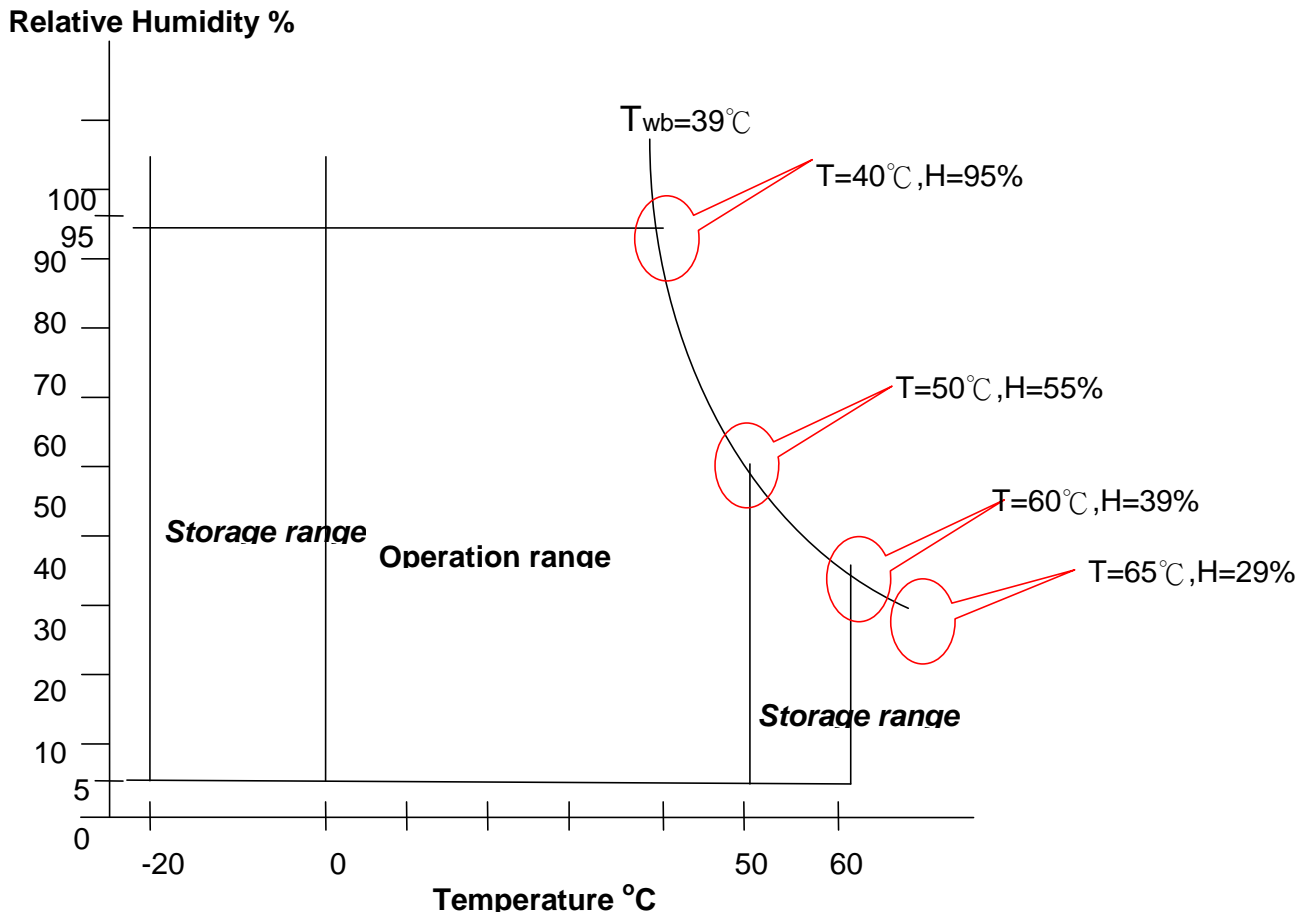

4.0 Optical Characteristics

The optical characteristics are measured under stable conditions at 25°C (Room Temperature):

Item	Unit	Conditions	Min.	Typ.	Max.
Viewing Angle	[degree]	Horizontal (Right)	50	60	
		CR = 10 (Left)	50	60	
	[degree]	Horizontal (Right)	60	75	
		CR =5 (Left)	60	75	
CR: Contrast Ratio	[degree]	Vertical (Upper)	30	40	
		CR = 10 (Lower)	50	60	
	[degree]	Vertical (Upper)	60	70	
		CR = 5 (Lower)	65	75	
Contrast ratio		Normal Direction	300	400	-
Response Time(Note 1)	[msec]	Raising Time Ton (10%-90%)	-	4	6
	[msec]	Falling Time Toff (90%-10%)	-	12	17
	[msec]	Raising + Falling	-	16	23
Color / Chromaticity Coordinates (CIE)		Red x	0.587	0.617	0.647
		Red y	0.317	0.347	0.377
		Green x	0.260	0.290	0.320
		Green y	0.563	0.593	0.623
		Blue x	0.118	0.148	0.178
		Blue y	0.070	0.100	0.130
Color Coordinates (CIE) White		White x	0.283	0.313	0.343
		White y	0.299	0.329	0.359
Brightness Uniformity	[%]		75	80	-
White Luminance at CCFL 8.0mA	[cd/m ²]		200	250	-
White Luminance at CCFL 6.5mA			170	200	-
Crosstalk (in 60Hz)	[%]				1.2

Note 1: Definition of Response time:

The output signals of photodetector are measured when the input signals are changed from “Black” to “White” (falling time), and from “White” to “Black” (rising time), respectively. The response time interval between the 10% and 90% of amplitudes. Refer to figure as below.

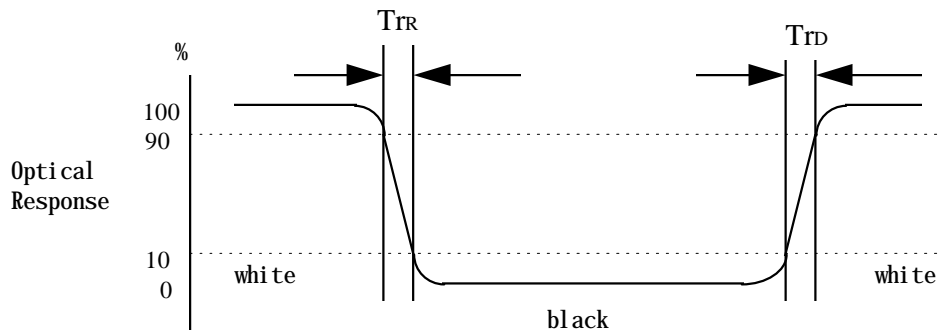

5.0 Signal Interface

5.1 Module Interface Connectors

Physical interface is described as for the connector on module.

These connectors are capable of accommodating the following signals and will be following components

Connector Name	Interface Connector
Manufacturer	Hirose, PTWO or compatible
Type / Part Number	DF-14H-20P-1.25H (Hirose) CWY20G-A0D1T (PTWO)

5.2 Module Connector Pin Configuration

DF-14H-20P-1.25H (Hirose) or CWY20G-A0D1T (PTWO)		
Pin No.	Symbol	Description
1	VDD	Power Supply, 3.3V (typical)
2	VDD	Power Supply, 3.3V (typical)
3	VSS	Ground
4	VSS	Ground
5	Rin0-	- LVDS differential data input (R0-R5, G0)
6	Rin0+	+ LVDS differential data input (R0-R5, G0)
7	VSS	Ground
8	Rin1-	- LVDS differential data input (G1-G5, B0-B1)
9	Rin1+	+ LVDS differential data input (G1-G5, B0-B1)
10	VSS	Ground
11	Rin2-	- LVDS differential data input (B2-B5, HS, VS, DE)
12	Rin2+	+ LVDS differential data input (B2-B5, HS, VS, DE)
13	VSS	Ground
14	ClKIN-	- LVDS differential clock input
15	ClKIN+	+ LVDS differential clock input
16	VSS	Ground
17	Rin3-	NC
18	Rin3+	NC
19	VSS	Ground
20	NC	Reserved

5.3 Backlight Connectors

Connector Name / Designation	For Lamp Connector
Manufacturer	JST or compatible
Type / Part Number	BHR-03VS-1
Mating Type / Part Number	SM02(8.0)B-BHS-1-TB

5.4 Backlight Connector Pin Configuration

Pin	Symbol	Description
1	HV	Lamp High Voltage
2	NC	No connection
3	LV	Ground

- u Cable length: 140 +- 5 mm
- u Connector-output position: right side (front view)
- u Lamp assy design shall be easy for replacement and repair.

5.5 Signal Electrical Characteristics

Each signal characteristics are as follows;

Item	Symbol	Min	Typ	Max	Unit
LCD Drive voltage	VDD	+3.0	+3.3	+3.6	[V]
“High” input signal voltage	Vih	2.0	-	-	[V]
“Low” input signal voltage	Vil	-	-	0.8	[V]

6bits input data format

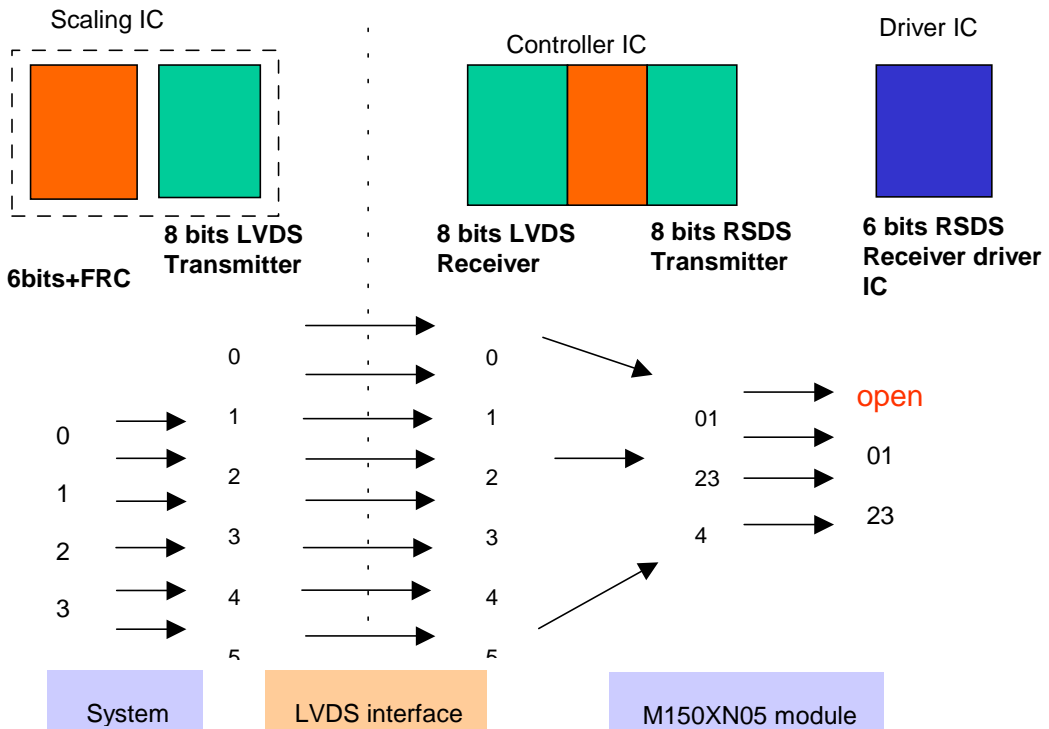
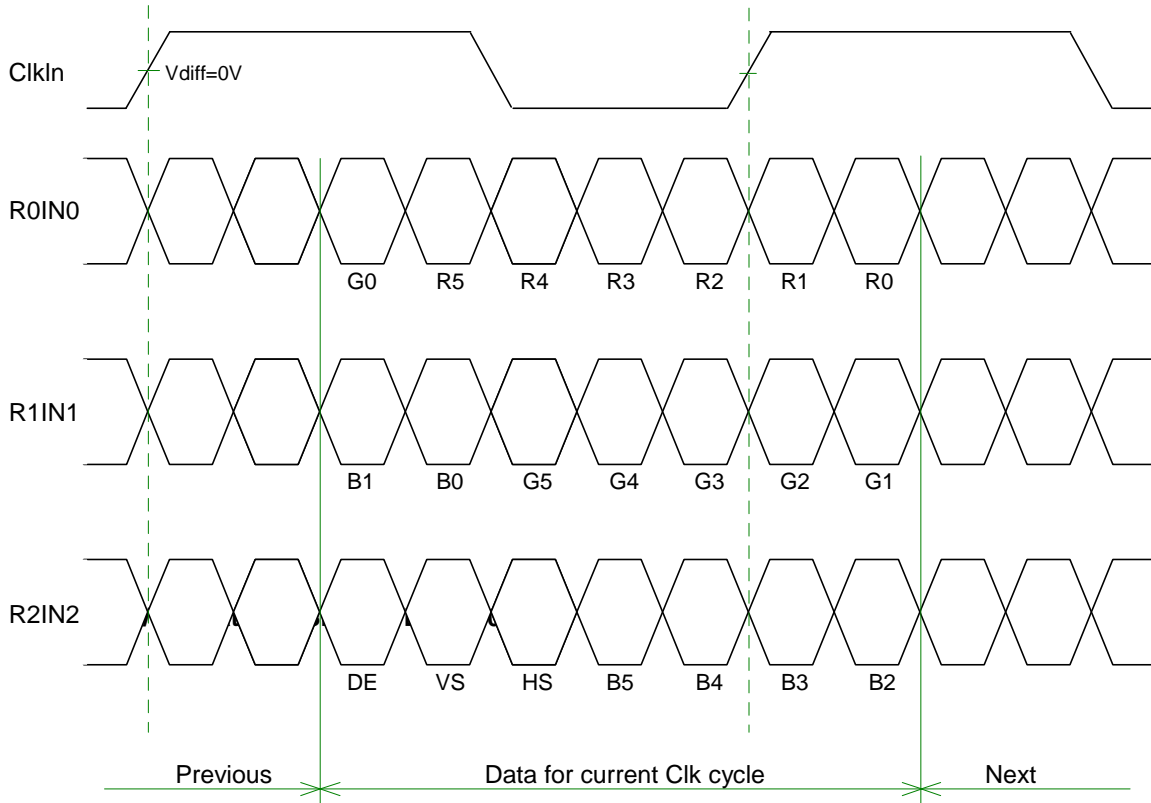

5.6 Signal Electrical Characteristics

Input signals shall be low or Hi-Z state when Vin is off

It is recommended to refer the specifications of SN75LVDS82DGG (Texas Instruments) in detail.

Each signal characteristics are as follows;

Parameter	Condition	Min	Max	Unit
Vth	Differential Input High Voltage(Vcm=+1.2V)		100	[mV]
Vtl	Differential Input Low Voltage(Vcm=+1.2V)	-100		[mV]

5.7 Interface Timings

Basically, interface timings described here is not actual input timing of LCD module but output timing of SN75LVDS82DGG (Texas Instruments) or equivalent.

5.7.1 Timing Characteristics

Signal	Item	Symbol	MIN	TYP	MAX	Unit
DTCLK	Freq.	Fdck		65	81	MHz
DTCLK	Cycle	Tck	12.3	15.4		ns
+V-Sync	Frame Rate	1/Tv		60	75	Hz
+V-Sync	Cycle	Tv	13.33	16.7		ms
+V-Sync	Cycle	Tv		806		lines
+V-Sync	Active level	Tva		6		lines
+V-Sync	V-back porch	Tvb		29		lines
+V-Sync	V-front porch	Tvf		3		lines
+DSPTMG	V-Line	M		768		lines
+H-Sync	Scan rate	1/Th		60		KHz
+H-Sync	Cycle	Th		1344		Tck
+H-Sync	Active level	Tha(*1)		136		Tck
+H-Sync	Back porch	Thb(*1)		160		Tck
+H-Sync	Front porch	Thf		24		Tck
+DSPTMG	Display Pixels	N		1024		Tck

Note: Typical value refer to VESA STANDARD

5.8 Interface Timing Definition

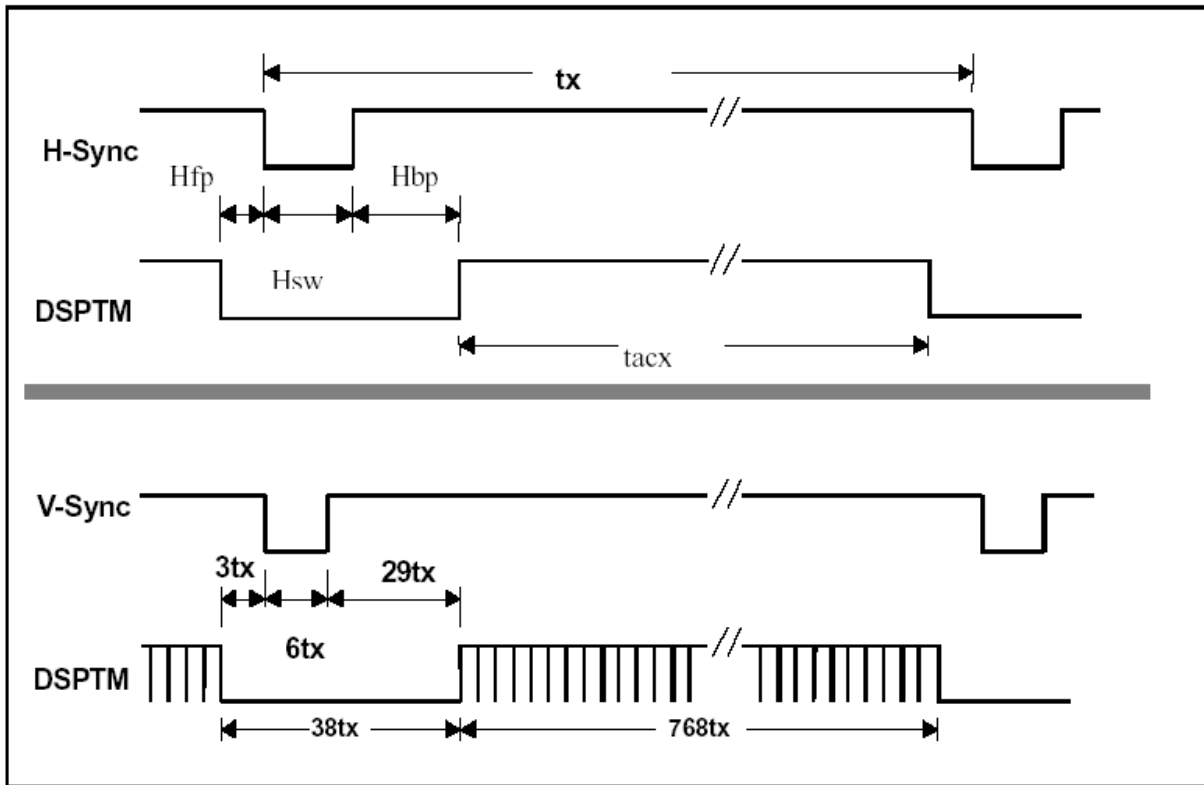

6.0 Pixel format image

Following figure shows the relationship of the input signals and LCD pixel format.

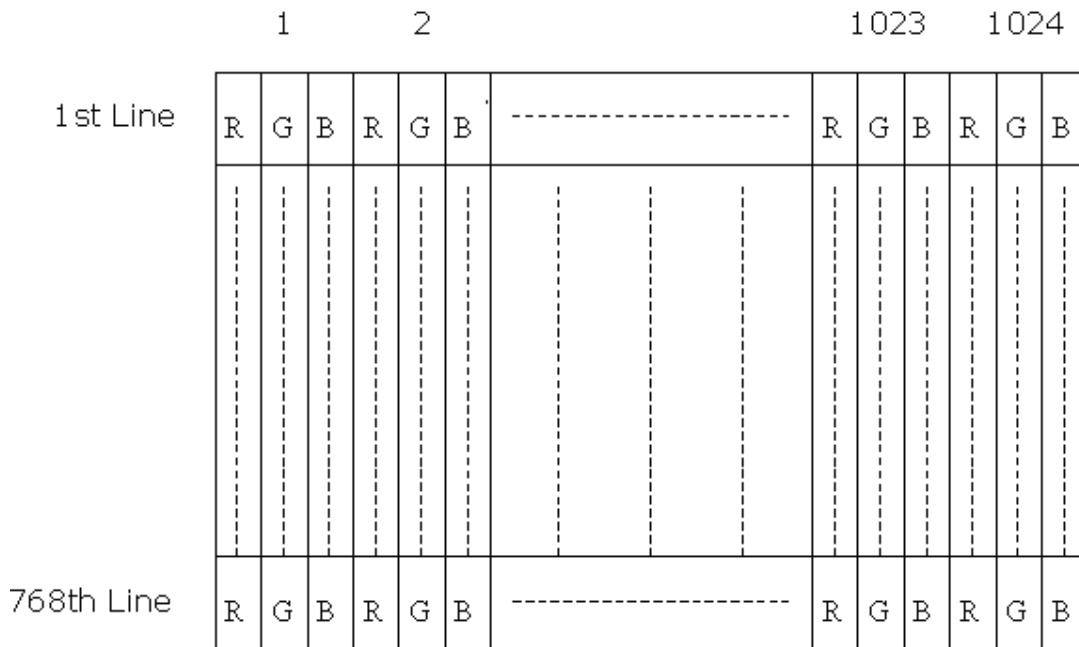

7.0 Power Consumption

Input power specifications are as follows;

Symbol	Parameter	Min	Typ	Max	Units	Condition
VDD	LCD Drive Voltage	3.0	3.3	3.6	[V]	
IDD	LCD Drive Current	-	1200	1500	[mA]	VDD=3.3v, All Black Pattern
PDD	LCD Drive power consumption	-	4.5	5	[Watt]	VDD=3.3v, All Black Pattern
VDDns	Allowable LCD Drive Ripple Noise			100	[mV] p-p	

8.0 Power ON/OFF Sequence

VDD power and lamp on/off sequence is as follows. Interface signals are also shown in the chart.

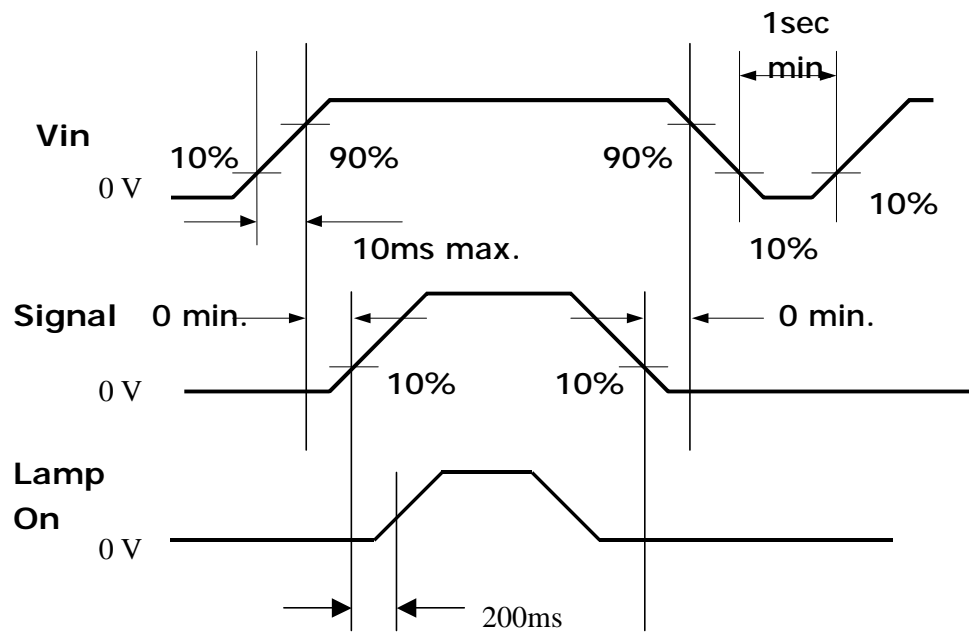

9.0 Backlight Characteristics

9.1 Signal for Lamp connector

Pin #	signal Name
1	Lamp High Voltage
2	No connection
3	Ground

9.2 Parameter guide line for CCFL Inverter

Symble	Parameter	Min	Typ	Max	Units	Condition
IRCFL	CCFL operation range	3.0	8.0	8.5	[mA] rms	(Ta=25°C) Note 4
ICFL	CCFL Inrush current	-	-	20	[mA]	
FCFL	CCFL Frequency	40	55	80	[KHz]	(Ta=25°C) Note 1
ViCFL (25°C) (reference)	CCFL Ignition Voltage	1000			[Volt] rms	(Ta= 25°C) Note 3
ViCFL (0°C) (reference)	CCFL Ignition Voltage	1300			[Volt] rms	(Ta= 0°C) Note 3
VCFL	CCFL Discharge Voltage (Reference)		590	650	[Volt] rms	(Ta=25°C) Note 2
PCFL	CCFL Power consumption @ 8mA (excluding inverter)		9.4	10.4	[Watt]	(Ta=25°C) Note 2

Note 1: CCFL Frequency should be carefully determined to avoid interference between inverter and TFT LCD

Note 2: Calculator value for reference (IRCFL×VCFL×2=PCFL)

Note 3: CCFL inverter should be able to give out a power that has a generating capacity of over 1300 voltage.
Lamp units need 1300 voltage minimum for ignition

Note 4: CCFL life time 30,000hr at 8mA, it's defined as when the brightness is reduced by half.
To exceed 8.0mA, life time will drop down dramatically.

10.0 Vibration, Shock, and Drop

10.1 Vibration & Shock

The module shall work error free after following vibration and shock condition. Likewise the module shall not sustain any damage after vibration and shock test.

10.1.1 Vibration Test Spec:

- I Frequency: 10 - 200Hz
- I Sweep: 30 Minutes each Axis (X, Y, Z)
- I Acceleration: 1.5G(10~200Hz P- P)
- I Test method:

Acceleration (G)	1.5
Frequency (Hz)	10~200~10
Active time (min)	30

10.1.2 Shock Test Spec:

Acceleration (G)	50
Active time(ms)	20
Wave form	Half-sin
Times	1

- I Direction: $\pm X$, $\pm Y$, $\pm Z$

10.2 Drop

Package test: The drop height is defined as 60 cm.

(1 corner, 3 edges, 6 flat faces)
-- No damage and defect found for panel.

11.0 Environment

The display module will meet the provision of this specification during operating condition or after storage or shipment condition specified below. Operation at 10% beyond the specified range will not cause physical damage to the unit.

11.1 Temperature and Humidity

11.1.1 Operating Conditions

The display module operates error free, when operated under the following conditions;

Temperature 0 °C to 50 °C
Relative Humidity 20% to 85%
Wet Bulb Temperature 39.0 °C

11.1.2 Shipping Conditions

The display module operates error free, after the following conditions;

Temperature -20 °C to 60 °C
Relative Humidity 5% to 95%
Wet Bulb Temperature 39.0 °C

11.2 Atmospheric Pressure

The display assembly is capable of being operated without affecting its operations over the pressure range as following specified:

	Pressure	Altitude
Maximum Pressure	1040 hPa	0 m = sea level
Minimum Pressure	601 hPa	3658 m = 12,000 feet

Note: Non-operation altitude limit of this display module = 40,000 feet. = 12193 m.

11.3 Thermal Shock

The display module will not sustain damage after being subjected to 100 cycles of rapid temperature change. A cycle of rapid temperature change consists of varying the temperature from -20°C to 60°C, and back again.

Thermal shock cycle -20 °C for 30min
 60 °C for 30min

Power is not applied during the test. After temperature cycling, the unit is placed in normal room ambient for at least 4 hours before powering on.

12.0 Reliability

This display module and the packaging of that will comply following standards.

12.1 Failure Criteria

The display assembly will be considered as failing unit when it no longer meets any of the requirements stated in this specification. Only as for maximum white luminance, following criteria is applicable.

I **Maximum white Luminance shall be 75 cd/m² or more.**

12.2 Failure Rate

The average failure rate of the display module (from first power-on cycle till 1,000 hours later) will not exceed 1.0%. The average failure rate of the display module from 1,000 hours until 10,000 hours will not exceed 0.70% per 1000 hours.

12.2.1 Usage

The assumed usage for the above criteria is:

- I 220 power-on hours per month
- I 500 power on/off cycles per month
- I Maximum brightness setting
- I Operation to be within office environment (25⁰C typical)

12.2.2 Component De-rating

All the components used in this device will be checked the load condition to meet the failure rate criteria.

12.3 CCFL Life

The assumed CCFL Life will be longer than 30,000 hours under stable condition at 25±5 °C;

Standard current at 8.0 ±0.5 mA

Definition of life: brightness becomes 50% or less than the minimum luminance value of CCFL.

12.4 ON/OFF Cycle

The display module will be capable of being operated over the following ON/OFF Cycles.

ON/OFF	Value	Cycle
+VDD and CCFL power	36,000	10 seconds on / 10 seconds off

13.0 Safety

13.1 Sharp Edge Requirements

There will be no sharp edges or corners on the display assembly that could cause injury.

13.2 Materials

13.2.1 Toxicity

There will be no carcinogenic materials used anywhere in the display module. If toxic materials are used, they will be reviewed and approved by the responsible AUO Toxicologist.

13.2.2 Flammability

All components including electrical components that do not meet the flammability grade UL94-V1 in the module will complete the flammability rating exception approval process. The printed circuit board will be made from material rated 94-V1 or better. The actual UL flammability rating will be printed on the printed circuit board.

14.0 Other requirements

14.1 Smoke Free Design

Any smoke nor strange smell shall not be observed by the operator at any single failure.

14.2 National Test Lab Requirement

The display module will satisfy all requirements for compliance to the following requirement:

UL 1950, First Edition	U.S.A. Information Technology Equipment
CSA C22.2 No.950-M89	Canada, Information Technology Equipment
IEC 950	International, Information Technology Equipment
EN 60 950	International, Information Processing Equipment (European Norm for IEC950)

The construction of the display module is designed to suppress EMI. When mounted into a specified host system, the system will meet the following EMI requirement:

FCC Part 15 Class B
VCCI Class 2
CISPR 22, class B
Taiwan CNS standard
China CCIB standard

15.0 Label

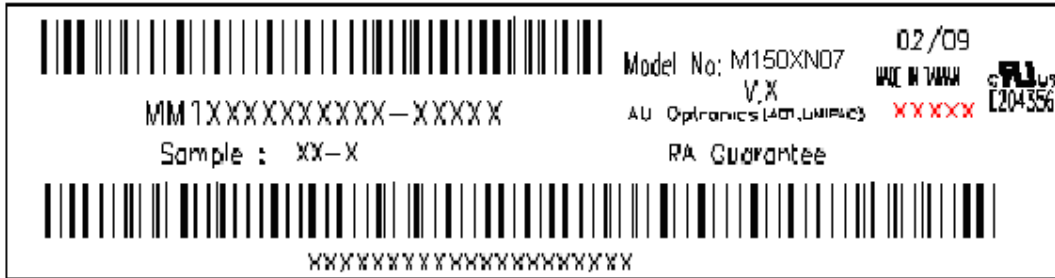

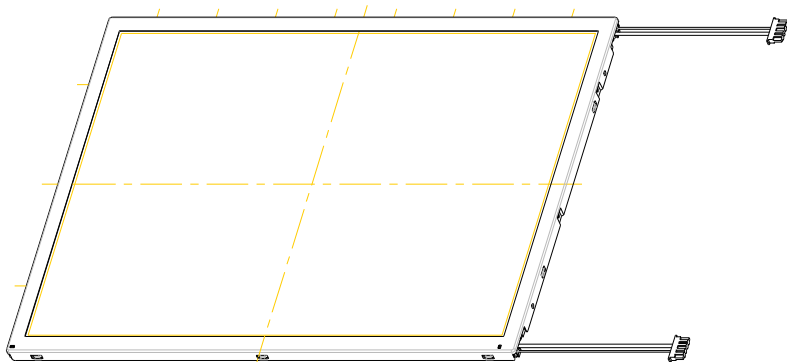

NOTE:

- 1.THE DIMENSION EXCLUDES DEFORMATION.
- 2.TOLERANCE WITHOUT NOTICED TO BE $\pm 0.5\text{mm}$
- 3.LAMP CABLE CONNECTOR TO BE JST BHR-03VS-1.
- 4.I/F CONNECTOR TO BE CWY 20G-A0D1P
- 5.M2 STAND-OFF TORQUE 2.0 KGF-cm MAX.
- 6.TORQUE OF M3 USER HOLE SHOULD BE WITHIN 4.0 KGF-CM AND RESCREW 10 TIMES.
- 7.GAP BETWEEN BEZEL FRONT INNER WALL AND UPPER POLARIZER TO BE $\pm 0.5\text{mm}$ MAX.
- 8.GAP BETWEEN BEZEL FRONT AND SHIELDING PLATE TO BE $\pm 0.5\text{mm}$ MAX.
- 9.CHECK CODE: ① ~ ③

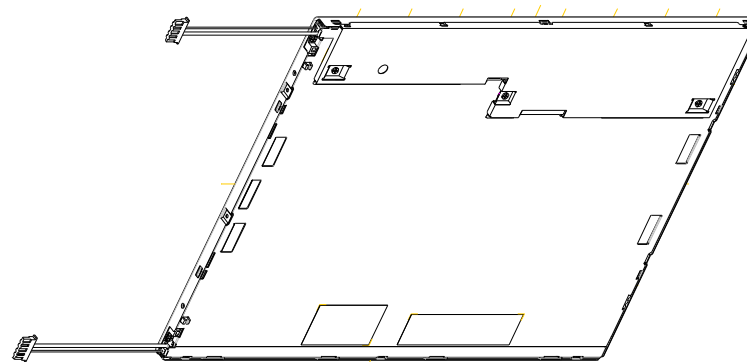

(C) Copyright AU Optronics, inc.

Feb. 2003 All Rights Reserved.

No Reproduction and Redistribution Allowed.

M150XN07

Ver0.1

25/28

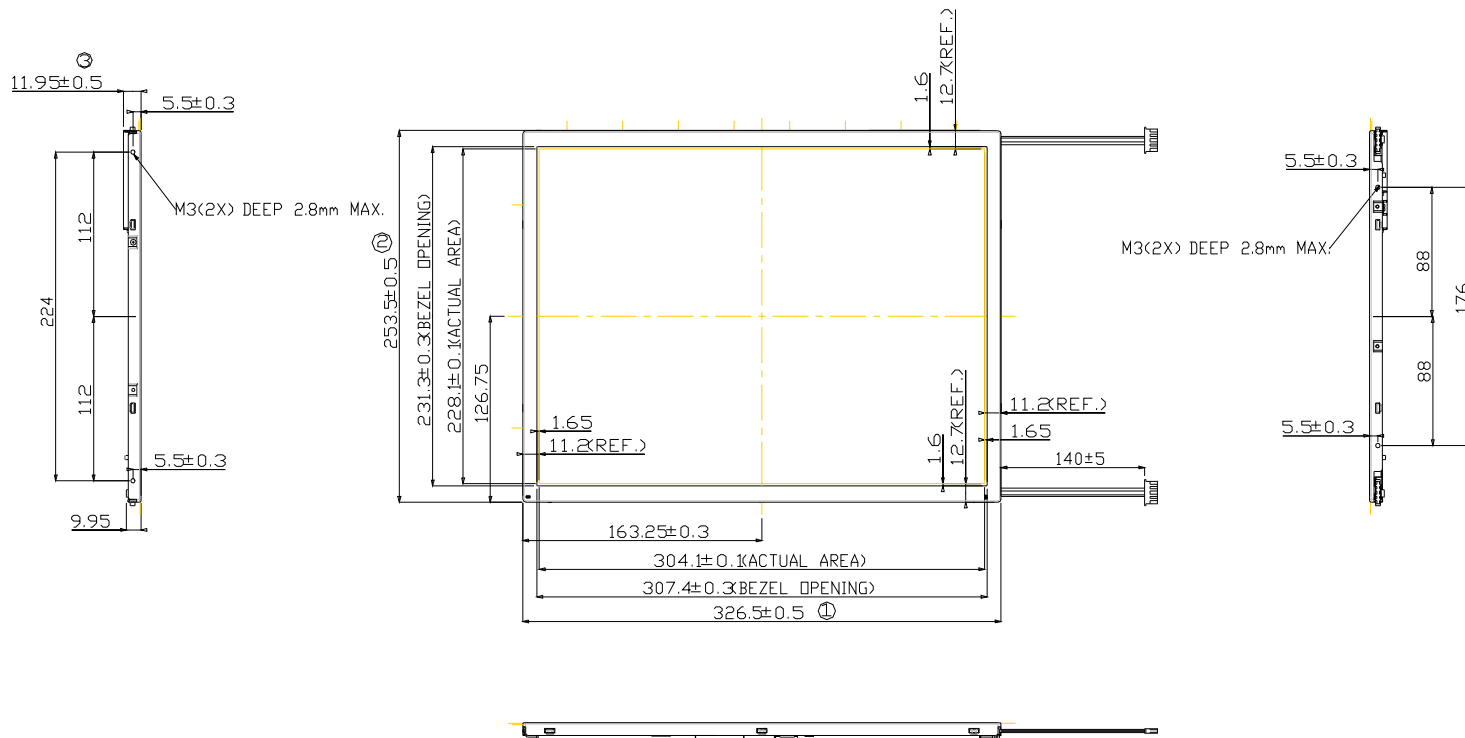

(C) Copy

Feb. 2003 All Rights Reserved.

M150XN07

Ver.0.1

26/28

No Reproduction and Redistribution Allowed.

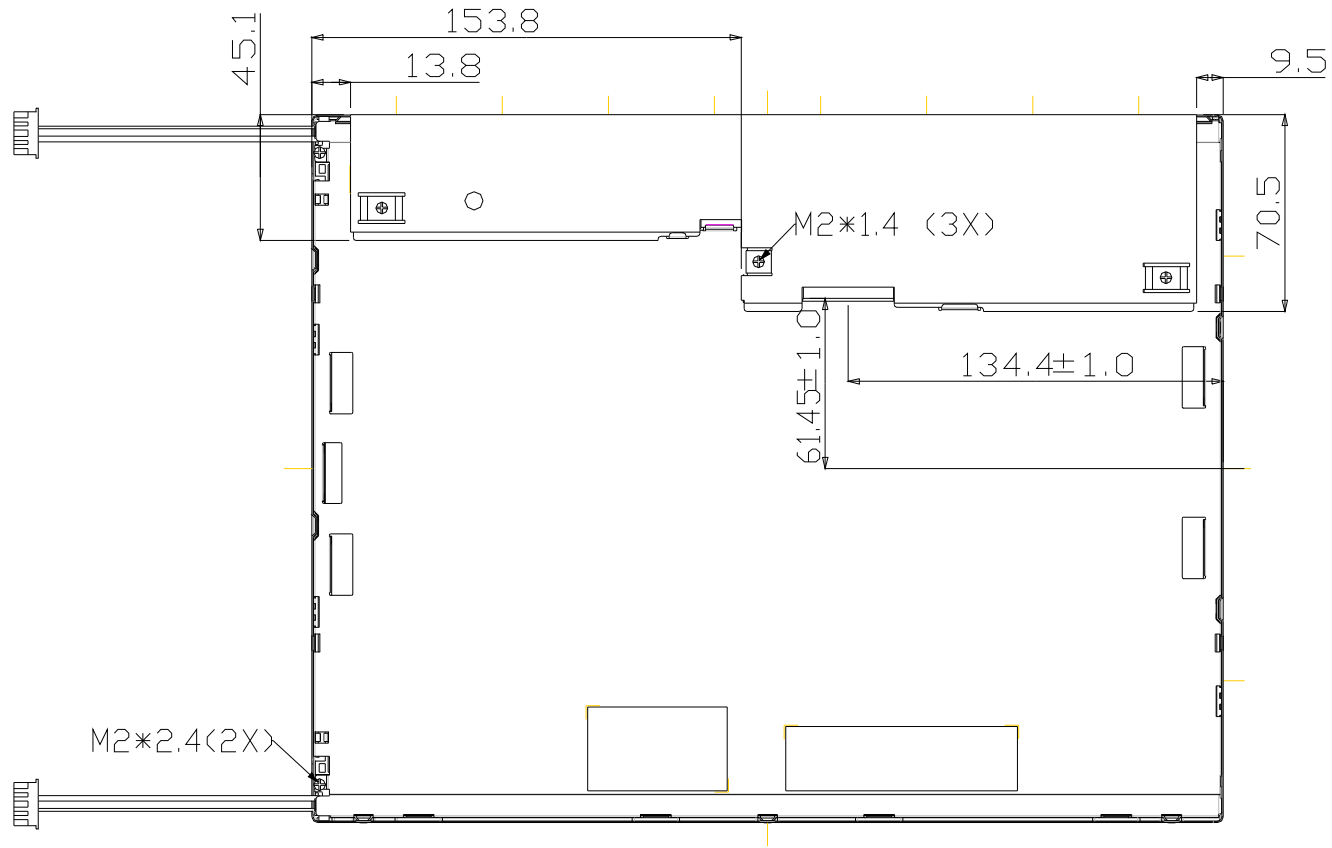

(C) Copyright AU Optronics, Inc.

Feb. 2003 All Rights Reserved.

M150XN07

Ver0.1

27/28

No Reproduction and Redistribution Allowed.